

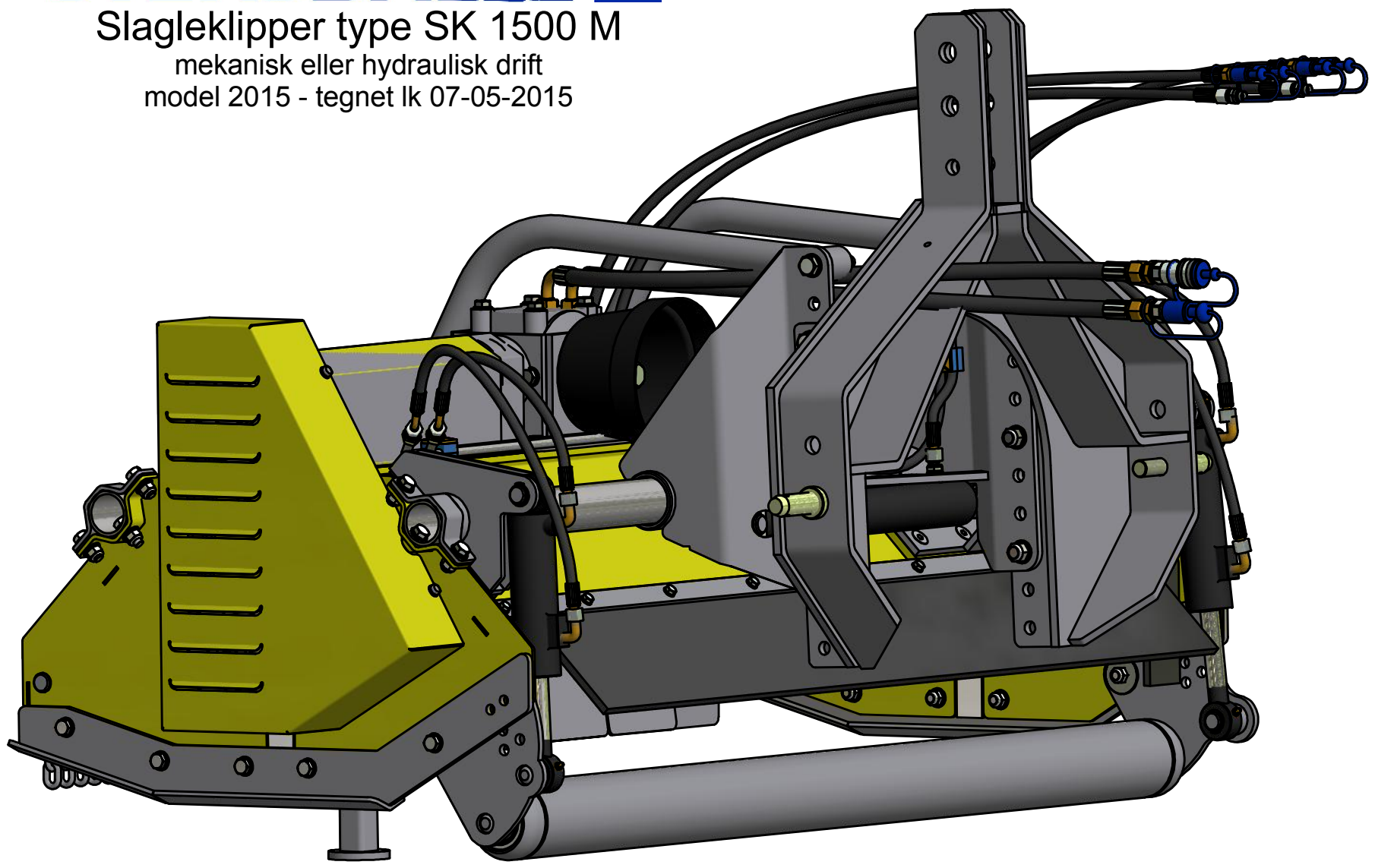

Slagleklipper type SK 1500 M
mekanisk eller hydraulisk drift
model 2015 - tegnet lk 07-05-2015



STENSBALLE

Slagleklipper type SK 1500 M

model 2015 - Afskærmning

tegnet Ik 07-05-2015

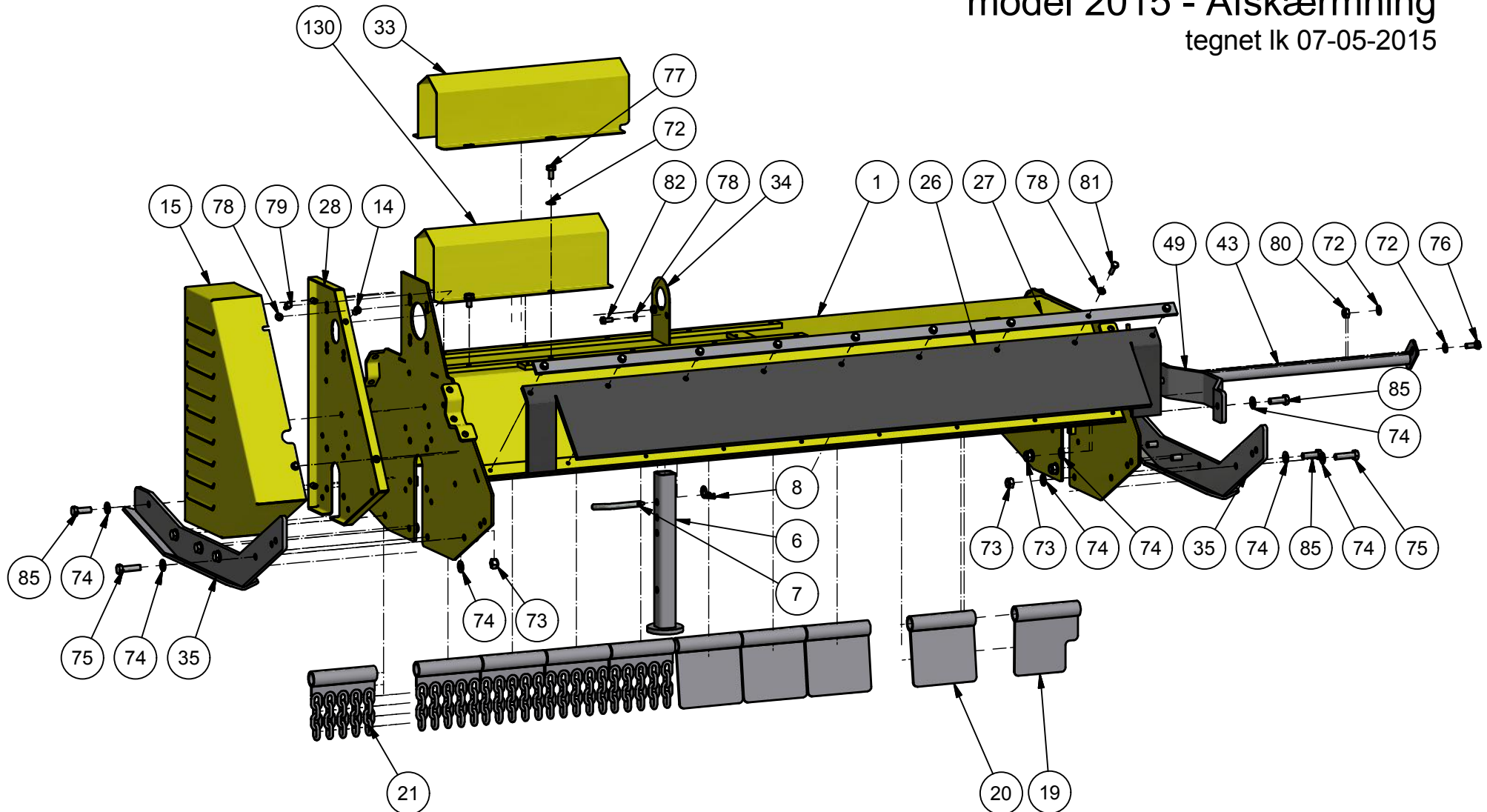

STENSBALLE

Slagleklipper type SK 1500 M
model 2015 - Transmission mek.
tegnnet lk 07-05-2015

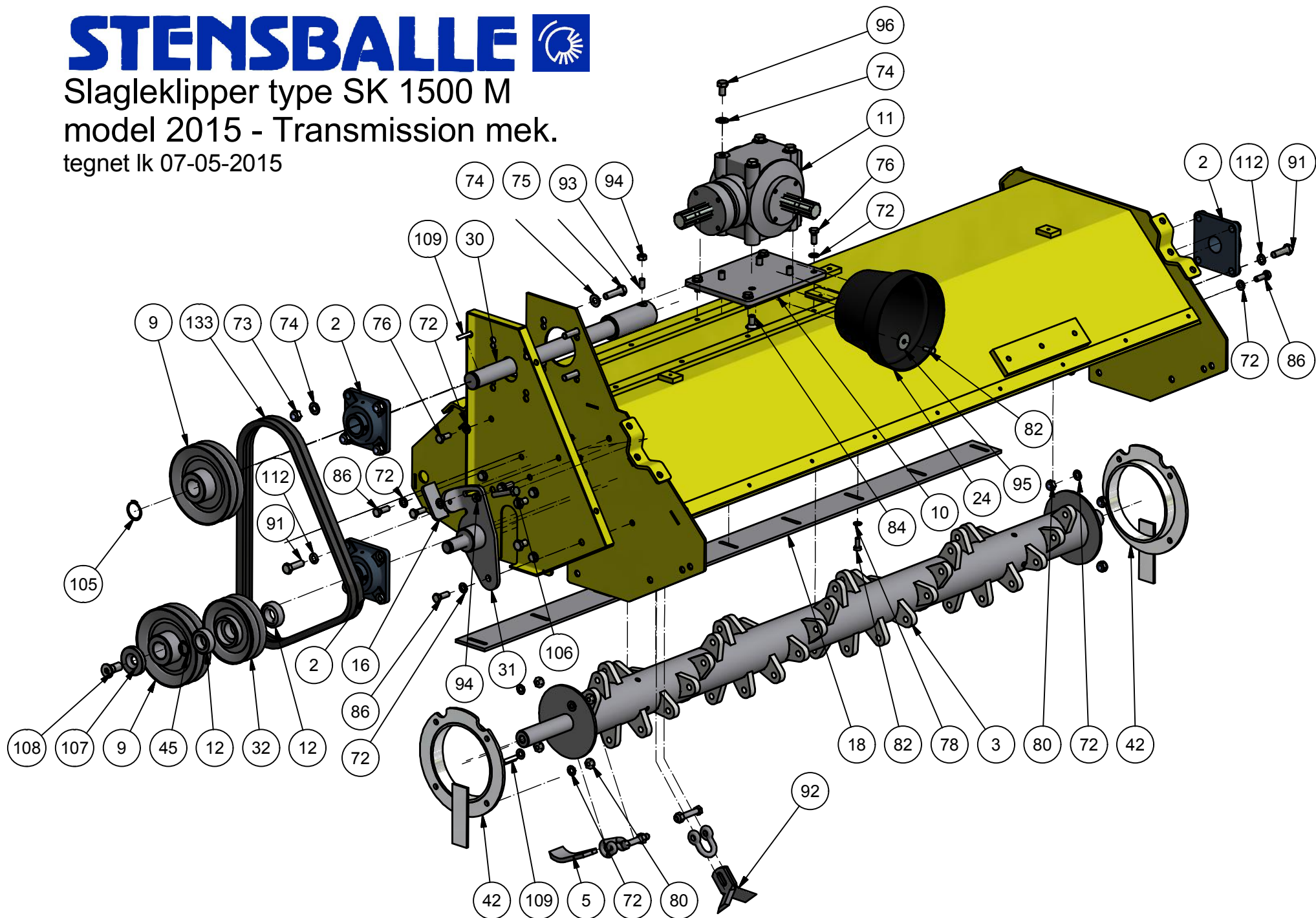

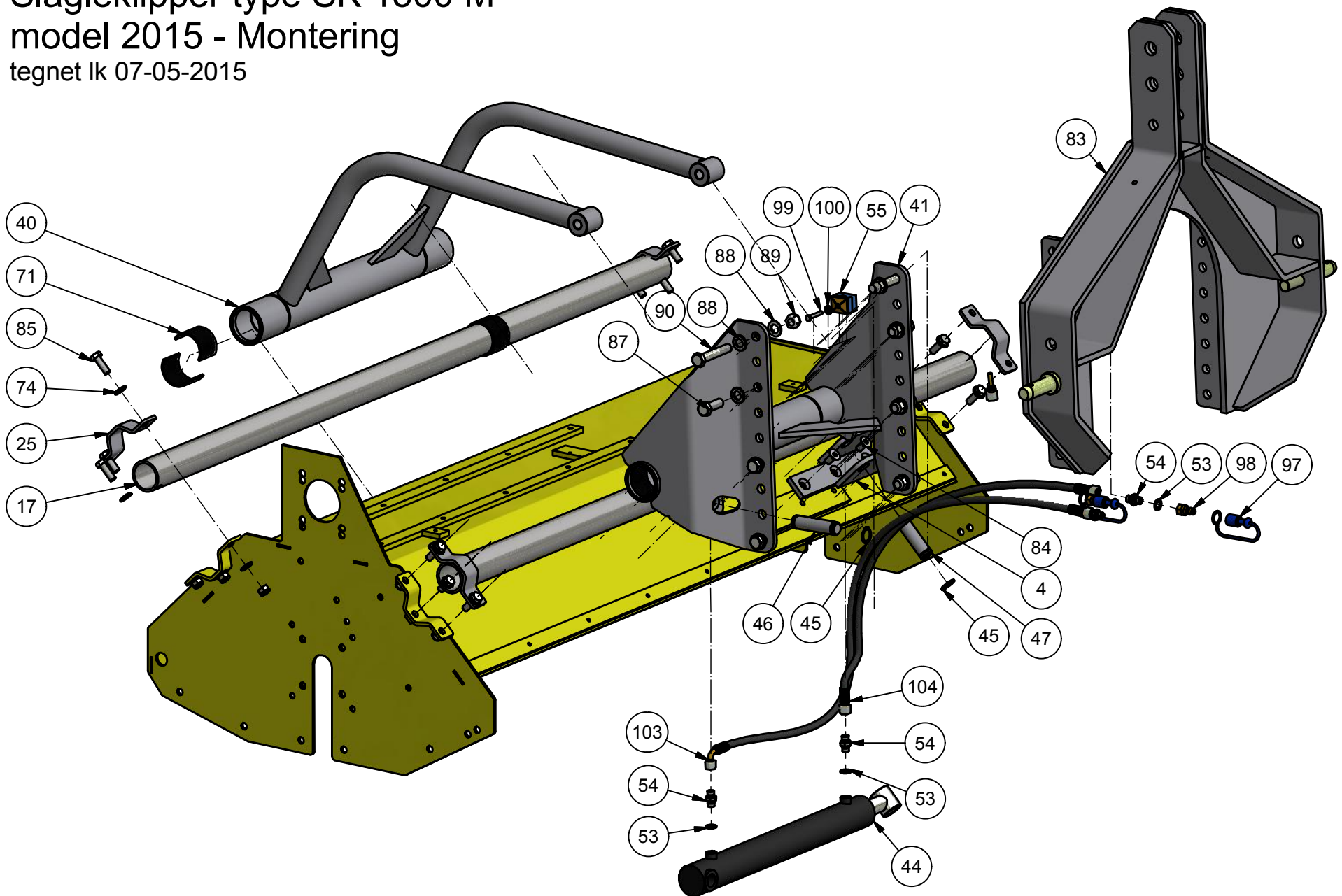

Slagleklipper type SK 1500 M
model 2015 - Hydraulisk højde
tegnnet lk 07-05-2015

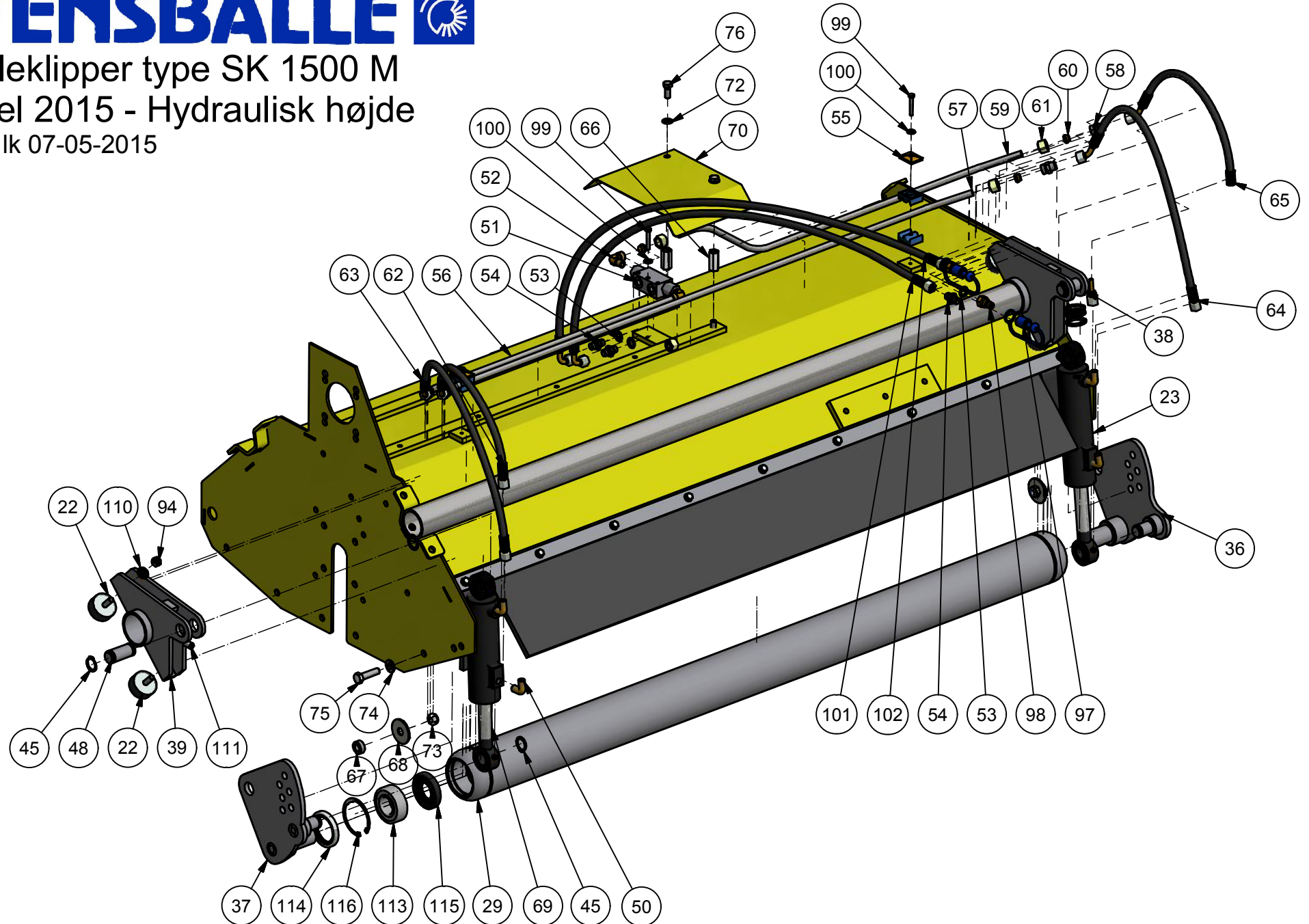

STENSBALLE

Slagleklipper type SK 1500 M
model 2015 - Hydraulisk drift
tegnet lk 07-05-2015

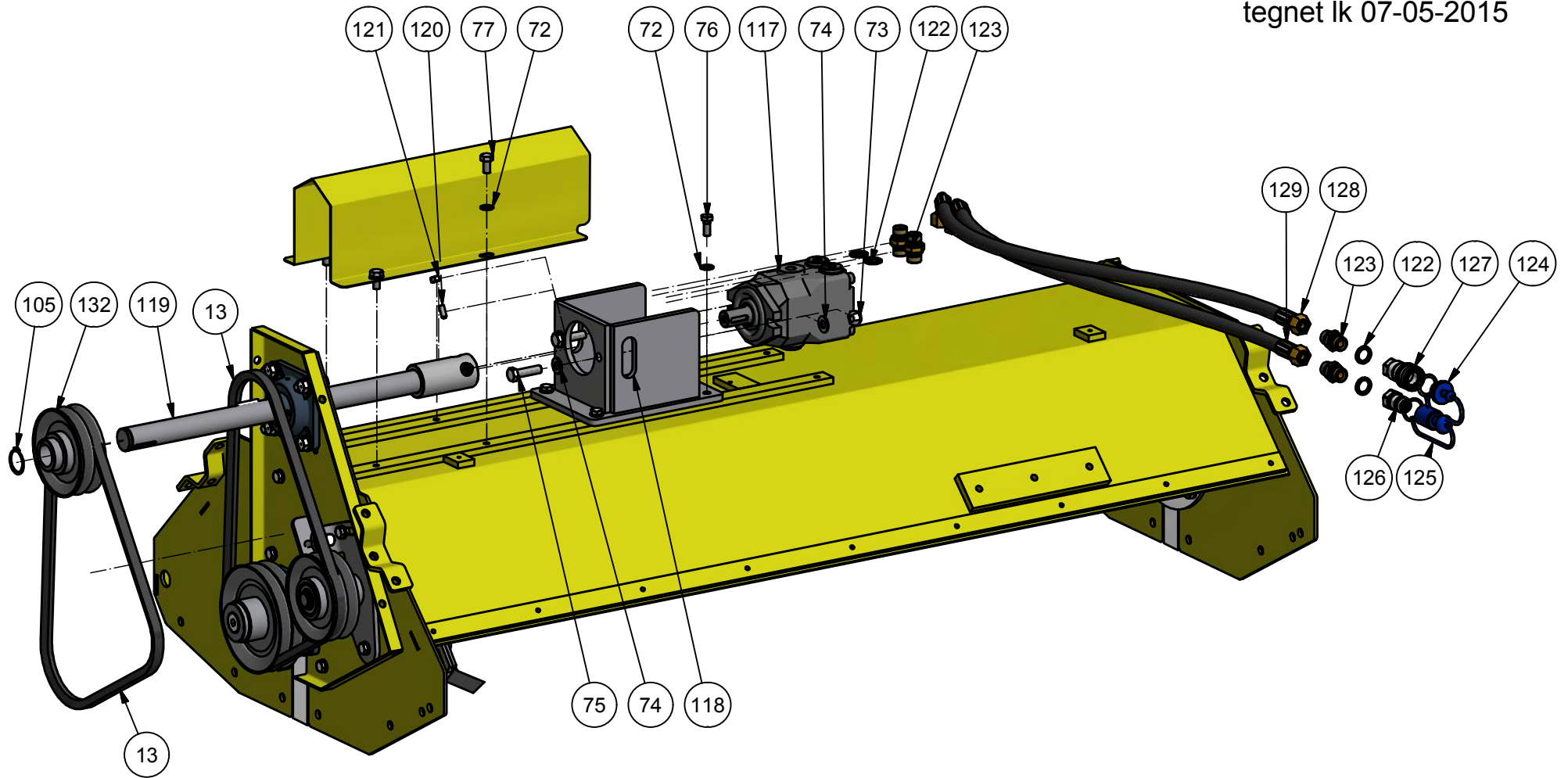

STENSBALLE

Slagleklipper type SK 1500 M

model 2015

tegnet lk 17-11-2015

Pos.	Benævnelse	Antal	Nummer	Bemærkning
1	Rotorbeskyttelse - komplet	1	78-504-510	
2	Flangeleje	3	54-500-207	
3	Slaglevalse - komplet	1	78-504-520	
4	Ankerbeslag for cylinder	1	78-504-220	
5	Spartelknivsæt komplet	48	18063 spartel komplet	
6	Støtteben	1	78-410-540	
7	Splitnagle	1	13-000-004	
8	Hårnålesplit	1	38-204-075	
9	Kileremskive B160/2	2	11-732-160	Opgiv maskinnummer
10	Gearplade - 2041	1	78-504-104	
11	Vinkelgear - 1000 o/m	1	S2041208060	
12	Kugleleje	2	54-016-205	
13	Kilerem - hydraulisk	2	SK_L rem01	Opgiv maskinnummer
14	Blindnittemøtrik	4	1111-08-017	
15	Dækskærm for transmission	1	78-504-103	
16	Vinkel for strammer	1	78-504-105	
17	Bærerør	2	78-504-501	
18	Modskær	1	78-504-503	
19	Klap - yderste	1	78-410-565	
20	Frontklap	4	78-410-560	
21	Kædesektion	5	78-410-567	
22	Gummibuffer	4	91-25-126	
23	Hydraulikcylinder med plungefunktion i enden	1	9796041	
24	PTO-afskærmning	1	49-190-200	
25	Spændebøjle - galvaniseret	4	78-504-101	
26	Gummi-afskærmning	1	78-504-504	
27	Holdeplade for gummi	1	78-504-502	
28	Ankerplade for transmission	1	78-504-102	
29	Bagrulle	1	78-504-530	
30	Drivaksel - mekanisk	1	78-504-540	
31	Beslag for remstrammer	1	78-504-140	
32	Strammeremskive	1	78-504-106	
33	PTO-skærm hydraulisk	1	78-504-509	

GMR 
Care for the ground

Saturnvej 17. DK 8700 Horsens
Tlf.: +4575643611 Fax: +45645320
E-mail: stensballe@gmr.dk Web: www.gmr.dk

STENSBALLE

Slagleklipper type SK 1500 M

model 2015

tegnet lk 17-11-2015

Pos.	Benævnelse	Antal	Nummer	Bemærkning
34	Lukkeplade	1	78-410-703	
35	Slæbesko	2	78-504-150	
36	Bagrullebeslag - højre	1	78-504-160	
37	Bagrullebeslag - venstre	1	78-504-165	
38	Cylinderbeslag - højre	1	78-504-170	
39	Cylinderbeslag - venstre	1	78-504-175	
40	Trækramme	1	78-504-190	
41	Hulrækkeramme	1	78-504-180	
42	Viklebeslag	2	78-504-210	
43	Nagle for frontklapper	1	N25x1590-30	
44	Cylinder	1	5030400F25	
45	Låsering	11	20-101-025	
46	Nagle for cylinderbund	1	78-504-201	
47	Nagle for cylindertop	1	78-504-202	
48	Cylindernagle - højdeindstilling	2	78-504-108	
49	Beskyttelse	1	78-504-109	
50	Vinkel	4	05BK04	
51	Kontraventil	1	BP2_07	
52	Indskruring	2	B12LR 1-4	
53	Bonded seal pakning	8	42-000-014	
54	Brystnippel	8	01BP04	
55	Db. Rørholder	3	1.12-12	
56	Tværrør nr.2	1	78-504-507	
57	Tværrør nr.1	1	78-504-506	
58	Redukt. samler	4	ER1210L	
59	Tværrør nr. 3	1	78-504-508	
60	Skærerings ø12	6	DS12L	
61	Omløber	6	M 12 L	
62	Højdeslange nr. 3	1	031-0350-FB040-FB044	
63	Højdeslange nr. 4	1	031-0500-FB040-FB044	
64	Højdeslange nr. 2	1	031-0500-FB040-FB044	
65	Højdeslange nr. 1	1	031-0350-FB040-FB044	
66	Langmøtrik	2	31-040-010	
67	Drejebøsning	2	78-504-203	

GMR 
Care for the ground

Saturnvej 17. DK 8700 Horsens
Tlf.: +4575643611 Fax: +45645320
E-mail: stensballe@gmr.dk Web: www.gmr.dk

STENSBALLE

Slagleklipper type SK 1500 M

model 2015

tegnet lk 17-11-2015

Pos.	Benævnelse	Antal	Nummer	Bemærkning
68	Svær skive M12 ø50	2	36-150-012	
69	Hydraulikcylinder med plungefunktion i enden	1	9796040	
70	Dækskærm - ventil	1	78-504-204	
71	Lejepande	8	78-504-205	
72	Facetskive	36	36-300-010	
73	Låsemøtrik	29	31-101-012	
74	Facetskive	61	36-300-012	
75	Sætskrue	8	29-112-045	
76	Sætskrue	8	29-110-025	
77	Sætskrue	4	29-110-020	
78	Facetskive	24	36-300-008	
79	Sætskrue	4	29-108-016	
80	Låsemøtrik	12	31-101-010	
81	Sætskrue	9	29-108-030	
82	Sætskrue	15	29-108-020	
83	Monteringsramme	1	05-200-200	
84	Unbracoskrue	7	32-012-025	
85	Sætskrue	21	29-112-035	
86	Sætskrue	14	29-110-030	
87	Sætskrue	6	29-116-045	
88	Facetskive	16	36-300-016	
89	Låsemøtrik	8	31-101-016	
90	Maskinbolt	2	28-116-090	
91	Sætskrue	8	29-112-040	
92	Y-knivsæt komplet	48	18063 komplet	
93	Pinolskrue	1	32-210-020	
94	Møtrik	6	31-001-010	
95	Skærmskive	4	36-200-008	
96	Sætskrue	4	29-112-020	
97	Støvhætte	4	39-004-002	
98	Lynkobling - 1/4" han	4	39-004-041	
99	Maskinbolt	4	28-106-040	
100	Contact-skive	4	35-200-006	

GMR 
Care for the ground

Saturnvej 17. DK 8700 Horsens
Tlf.: +4575643611 Fax: +45645320
E-mail: stensballe@gmr.dk Web: www.gmr.dk

STENSBALLE

Slagleklipper type SK 1500 M

model 2015

tegnet lk 17-11-2015

Pos.	Benævnelse	Antal	Nummer	Bemærkning
101	Slange traktor - højde 1	1	031-1500-FB040-FB049	
102	Slange traktor - højde 2	1	031-1500-FB040-FB049	
103	Slange traktor - sideforsk 1	1	031-1500-FB040-FB049	
104	Slange traktor - sideforsk 2	1	031-1100-FB040-FB040	
105	Låsering	1	20-001-035	
106	Sætskrue	1	29-110-060	
107	Specialskive	1	78-504-206	
108	Undersænket unbracoskrue	1	32-016-040	
109	Pasfeder A	2	34-108-740	
110	Contact-skive	6	35-200-010	
111	Pinolskrue	2	32-212-020	
112	Centerfjederskive	8	35-400-012	
113	Rulleleje	2	54-102-207	
114	Pakdåse - yderste	2	14-725-008	
115	Pakdåse - inderste	2	14-723-510	
116	Låsering	2	20-002-072	
117	Hydraulikmotor	1	M4MF28-28-3BA-A7	Opgiv maskinnummer
118	Motorkonsol	1	78-504-230	
119	Drivaksel komplet	1	78-504-550	
120	Pinolskrue	2	32-208-020	
121	Møtrik	2	31-001-008	
122	Bonded seal pakning	4	42-000-012	
123	Brystnippel	4	01BP08	
124	Støvprop	1	39-008-001	
125	Støvhætte	1	39-008-002	
126	Lynkobling - 1/2" han	1	39-008-081	
127	Lynkobling hunstik	1	39-008-082	
128	Driftslange nr. 1	1	033-1500-FB080-FB089	
129	Driftslange nr. 2	1	033-1500-FB080-FB089	
130	PTO-skærm mekanisk	1	78-504-505	
131	Sætskrue	1	29-112-025	
132	Kileremskive - hydraulisk	1	11-732-125	Opgiv maskinnummer
133	Kilerem - mekanisk	2	10-003-XXX	Opgiv maskinnummer

GMR 
Care for the ground

Saturnvej 17. DK 8700 Horsens
Tlf.: +4575643611 Fax: +45645320
E-mail: stensballe@gmr.dk Web: www.gmr.dk