

STENSBALLE

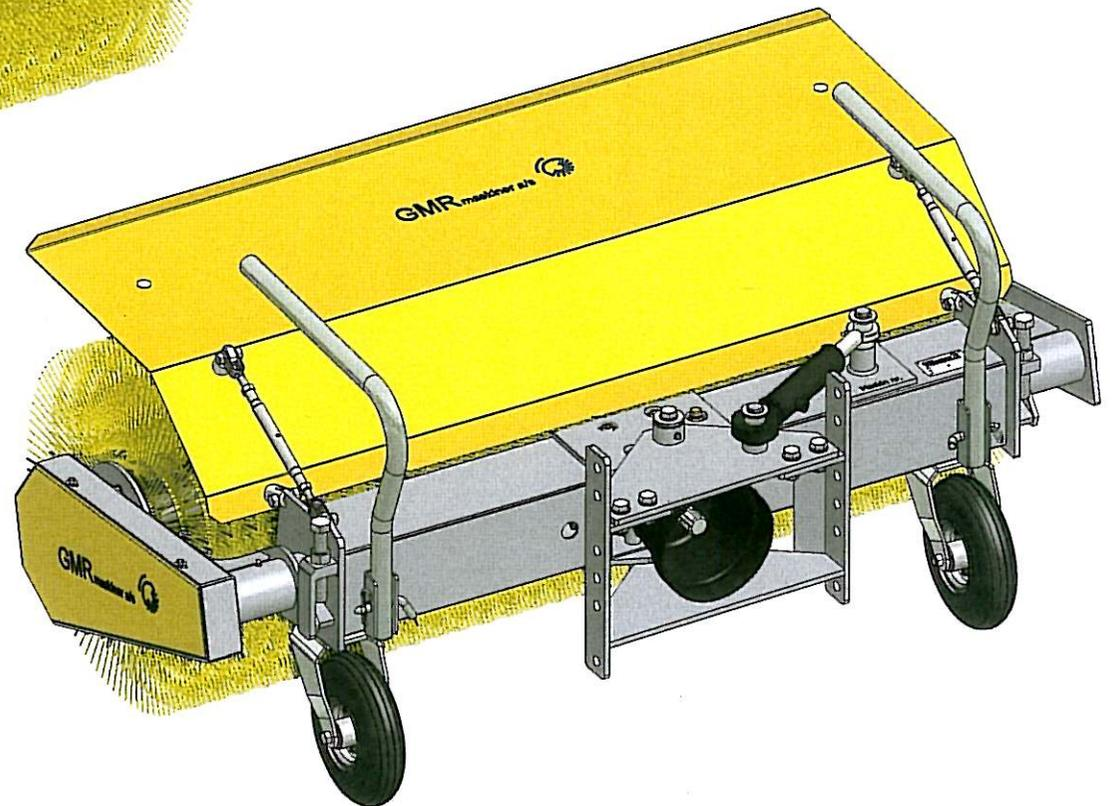

Fejemaskine type FF/MA

Model 2002 - 23.03.2010

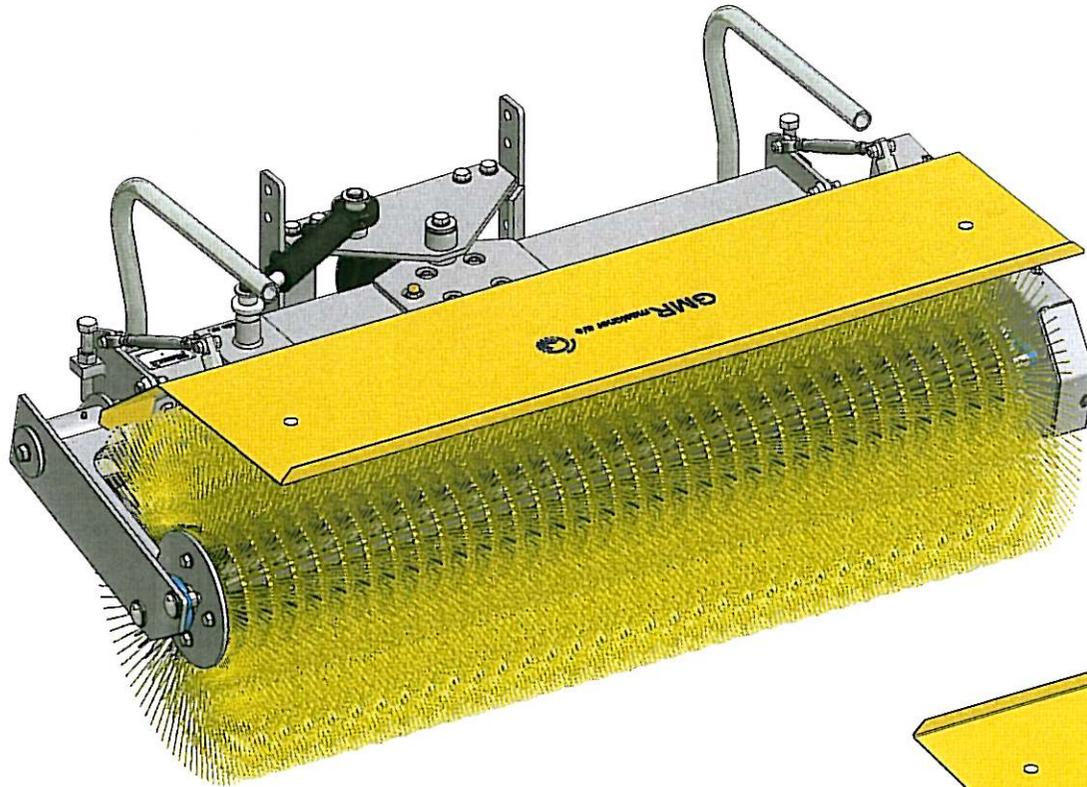



Fejemaskine type FF/MA

Model 2002 - 25.03.2010

Bom

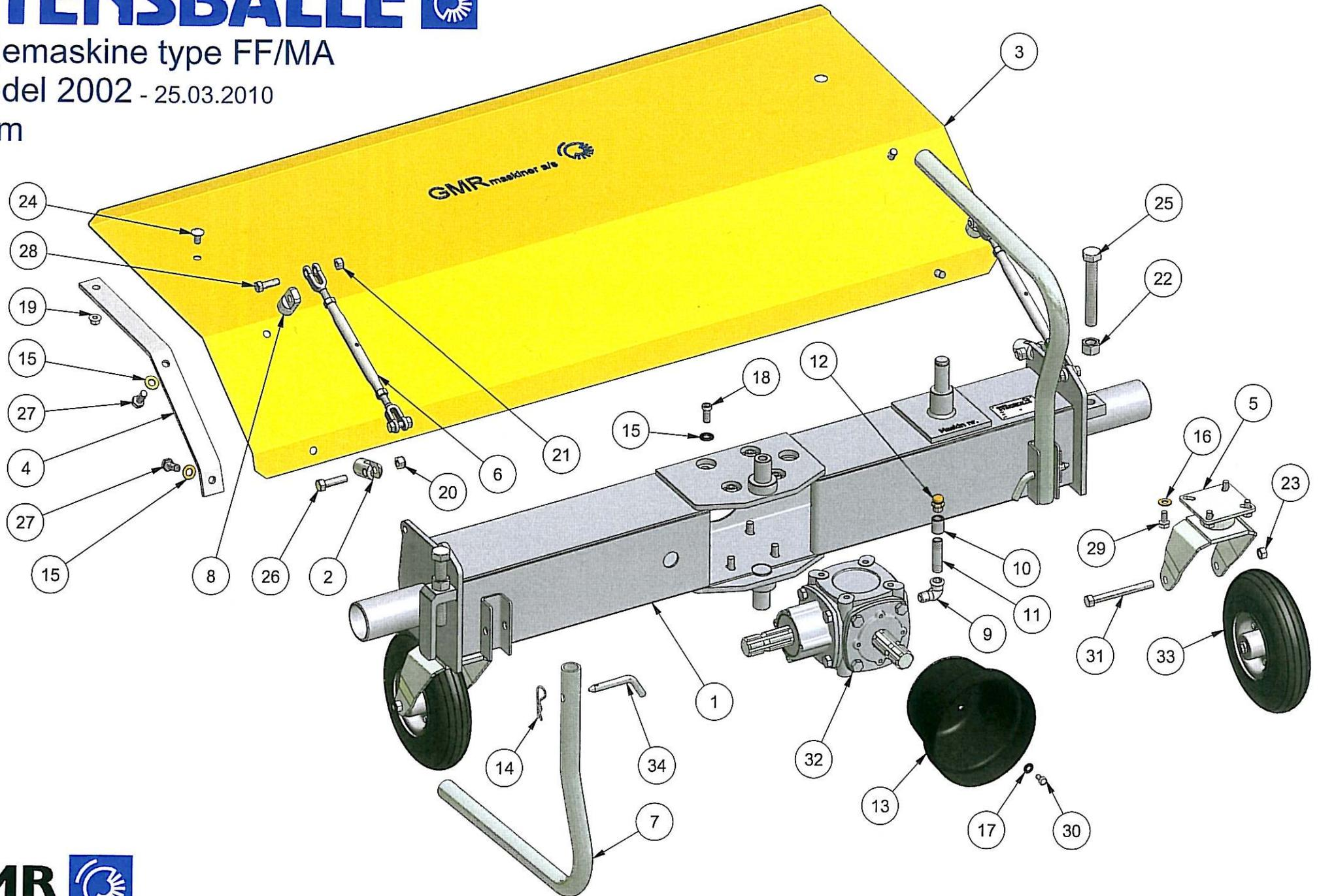

STENSBALLE

Fejemaskine type FF/MA

Model 2002 - Bom

25.03.2010

Pos.	Benævnelse	Antal	Nummer	Bemærkning
1	Hovedbom	1	89-611-540	FF 1100 MA
	Hovedbom	1	89-611-550	FF 1200 MA
	Hovedbom	1	89-611-100	FF 1300 MA
	Hovedbom	1	89-611-500	FF 1500 MA
	Hovedbom	1	89-806-500	FF 1700 MA
2	Skærmstropgaffel - neders	2	89-611-005	
3	Børsteskaerm	1	89-611-010	FF 1100 MA
	Børsteskaerm	1	89-611-003	FF 1200 MA
	Børsteskaerm	1	89-611-001	FF 1300 MA
	Børsteskaerm	1	89-611-004	FF 1500 MA
	Børsteskaerm	1	89-806-504	FF 1700 MA
4	Skærmband	2	89-611-002	
5	Hjulgaffel	2	73-310-012	
6	Vantskrue	2	59-012-212	
7	Støtteben	2	53-213-042	
8	Skærmstropbolt	2	53-100-001	
9	Pibehoved	1	50-592-038	
10	Gevindmuffe	1	50-300-038	
11	Nippelrør	1	50-206-038	
12	Udluftningsprop	1	50-111-038	
13	PTO-afskærmning	1	49-190-200	
14	Hårnålesplit	2	38-203-070	
15	Contact-skive	12	35-200-012	
16	Contact-skive	8	35-200-010	
17	Contact-skive	4	35-200-008	
18	Unbracoskrue - rundh.	8	32-112-025	
19	Flangemøtrik	2	31-601-010	
20	Låsemøtrik	2	31-101-012	
21	Låsemøtrik	4	31-101-010	
22	Møtrik	2	31-001-020	
23	Møtrik	2	31-001-012	
24	Bræddebolt	2	30-110-020	
25	Sætskrue	2	29-120-130	
26	Sætskrue	2	29-112-045	

GMR
maskiner a/s



Salurnvej 17, DK 8700 Horsens
Tlf.: +45 75 64 36 11 . Fax: +45 75 64 53 20
E-mail: stensballe@gmr.dk . <http://www.gmr.dk>

STENSBALLE

Fejemaskine type FF/MA

Model 2002 - Bom

25.03.2010

Pos.	Benævnelse	Antal	Nummer	Bemærkning
1	Hovedbom	1	89-611-540	FF 1100 MA
	Hovedbom	1	89-611-550	FF 1200 MA
	Hovedbom	1	89-611-100	FF 1300 MA
	Hovedbom	1	89-611-500	FF 1500 MA
	Hovedbom	1	89-806-500	FF 1700 MA
2	Skærmstropgaffel	2	89-611-005	
3	Børsteskærm	1	89-611-010	FF 1100 MA
	Børsteskærm	1	89-611-003	FF 1200 MA
	Børsteskærm	1	89-611-001	FF 1300 MA
	Børsteskærm	1	89-611-004	FF 1500 MA
	Børsteskærm	1	89-806-504	FF 1700 MA
4	Skærmband	2	89-611-002	
5	Hjulgaffel	2	73-310-012	
6	Vantskrue	2	59-012-212	
7	Støtteben	2	53-213-042	
8	Skærmstropbolt	2	53-100-001	
9	Pibehoved	1	50-592-038	
10	Gevindmuffe	1	50-300-038	
11	Nippelrør	1	50-206-038	
12	Udluftningsprop	1	50-111-038	
13	PTO-afskærmning	1	49-190-200	
14	Hårnålesplit	2	38-203-070	
15	Contact-skive	12	35-200-012	
16	Contact-skive	8	35-200-010	
17	Contact-skive	4	35-200-008	
18	Unbracoskrue - rundh.	8	32-112-025	
19	Flangemøtrik	2	31-601-010	
20	Låsemøtrik	2	31-101-012	
21	Låsemøtrik	4	31-101-010	
22	Møtrik	2	31-001-020	
23	Møtrik	2	31-001-012	
24	Bræddebolt	2	30-110-020	
25	Sætskrue	2	29-120-130	
26	Sætskrue	2	29-112-045	

GMR
maskiner a/s



Saturnvej 17 . DK 8700 Horsens
Tlf.: +45 75 64 36 11 . Fax: +45 75 64 53 20
E-mail: stensballe@gmr.dk . <http://www.gmr.dk>

STENSBALLE

Rammedel type FF/MA

Model 2002 - 19.03.2010

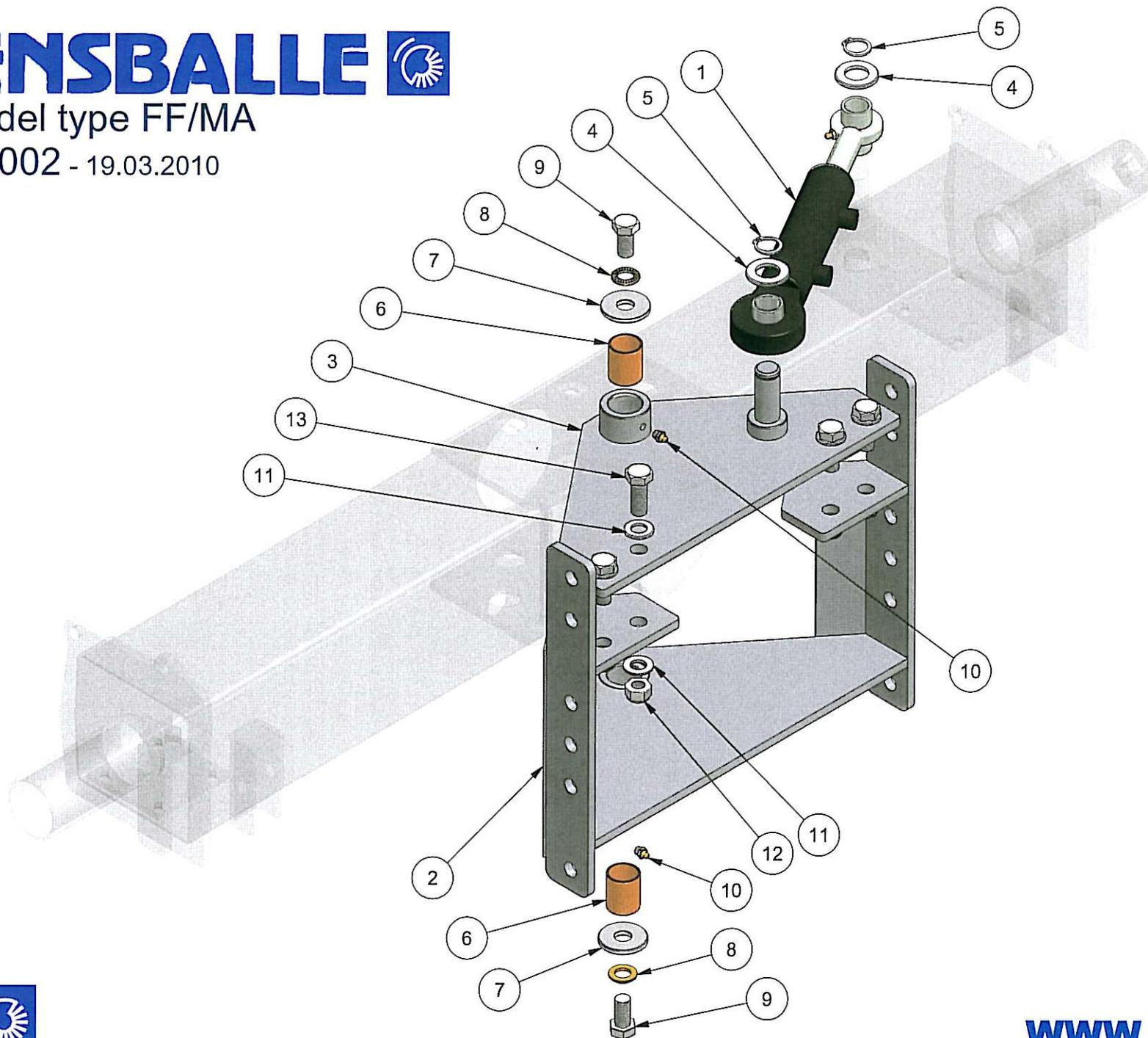

STENSBALLE

Rammedel type FF/MA

Model 2002

19.03.2010

<i>Pos.</i>	<i>Benævnelse</i>	<i>Antal</i>	<i>Nummer</i>	<i>Bemærkning</i>
1	Cylinder	1	01-340-205	
2	Bundbeslag for monteringsram	1	89-904-220	
3	Topbeslag for monteringsramm	1	89-904-210	
4	Facetskive	2	36-300-024	
5	Låsering	2	20-101-025	
6	Bronzebøsning	2	54-630-040	
7	Svær skive	2	36-150-016	
8	Contact-skive	2	35-200-016	
9	Sætskrue	2	29-116-030	
10	Smørenippel	2	57-000-010	
11	Facetskive	8	36-300-016	
12	Låsemøtrik	4	31-101-016	
13	Sætskrue	4	29-116-040	

GMR
maskiner a/s



Saturnvej 17 . DK 8700 Horsens
Tlf.: +45 75 64 36 11 , Fax: +45 75 64 53 20
E-mail: stensballe@gmr.dk . <http://www.gmr.dk>

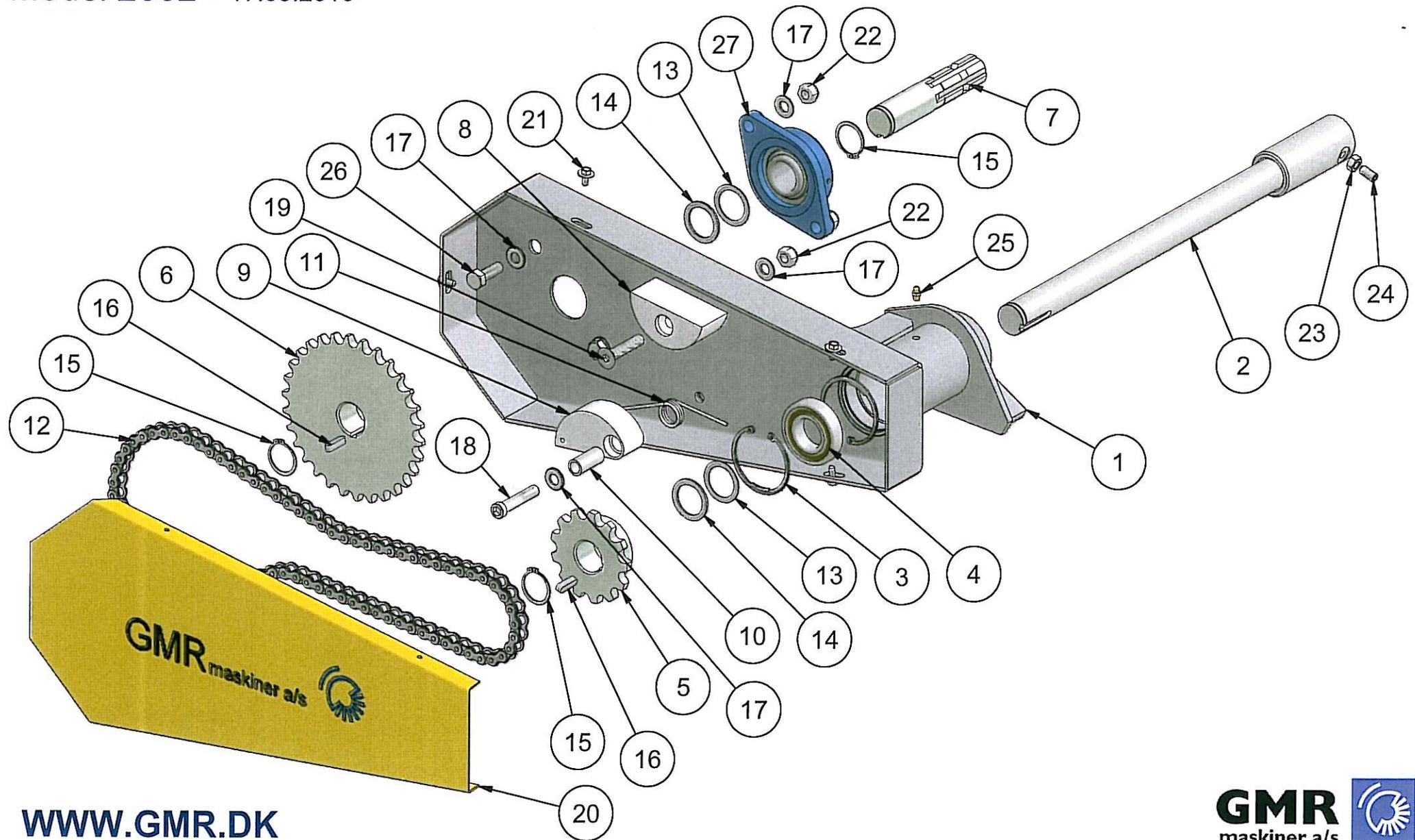

STENSBALLE

Venstre sidestykke type FF/MA

Model 2002

17.03.2010

Pos.	Benævnelse	Antal	Res. nummer	Bemærkning
1	Kædekasse	1	89-611-200	
2	Drivaksel	1	53-111-007	FF1100MA 540/1000 omdr./min
	Drivaksel	1	53-112-007	FF1100MA 2000 omdr./min.
	Drivaksel	1	53-112-007	FF1200MA 540/1000 omdr./min
	Drivaksel	1	53-113-007	FF1200MA 2000 omdr./min.
	Drivaksel	1	53-113-007	FF1300MA 540/1000 omdr./min
	Drivaksel	1	53-114-007	FF1300MA 2000 omdr./min.
	Drivaksel	1	53-115-007	FF1500MA 540/1000 omdr./min
	Drivaksel	1	53-116-007	FF1500MA 2000 omdr./min.
	Drivaksel	1	53-117-007	FF1700MA 540/1000 omdr./min
	Drivaksel	1	53-118-007	FF1700MA 2000 omdr./min.
3	Låsering	2	20-002-072	
4	Kugleleje	1	54-026-207	
5	Kædehjul - trækkende	1	24-121-113	540-1000-1500-2000 omdr/min.
6	Kædehjul - trukgende	1	24-121-127	540-1500 omdr/min.
	Kædehjul - trukgende	1	24-121-130	1000-2000 omdr/min.
7	Akseltap - venstre	1	53-113-009	
8	Glideklods fast	1	53-213-015	
9	Strammeklods	1	53-213-012	
10	Gliderør	1	53-213-013	
11	Fjeder for strammeklods	1	62-182-373	
12	Kæde inkl. samleled	1	22-121-063	540-1500 omdr/min.
	Kæde inkl. samleled	1	22-121-065	1000-2000 omdr/min.
	Løs samleled	1	23-121-000	
	Forkrøbbet samleled	1	23-121-111	Kan forekomme

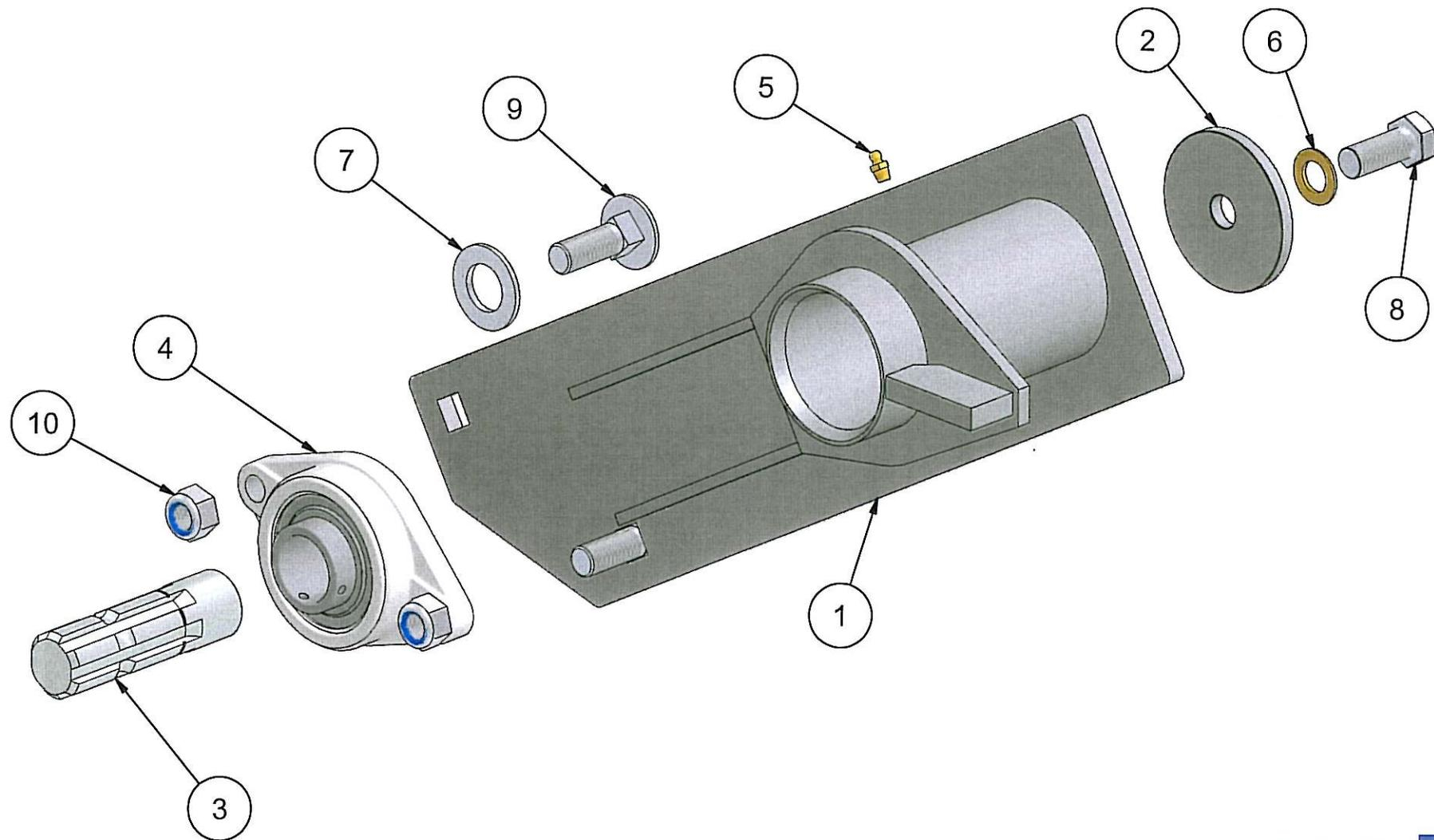

STENSBALLE

Børstevealse type FF/MA

Model 2002 - 17.03.2010

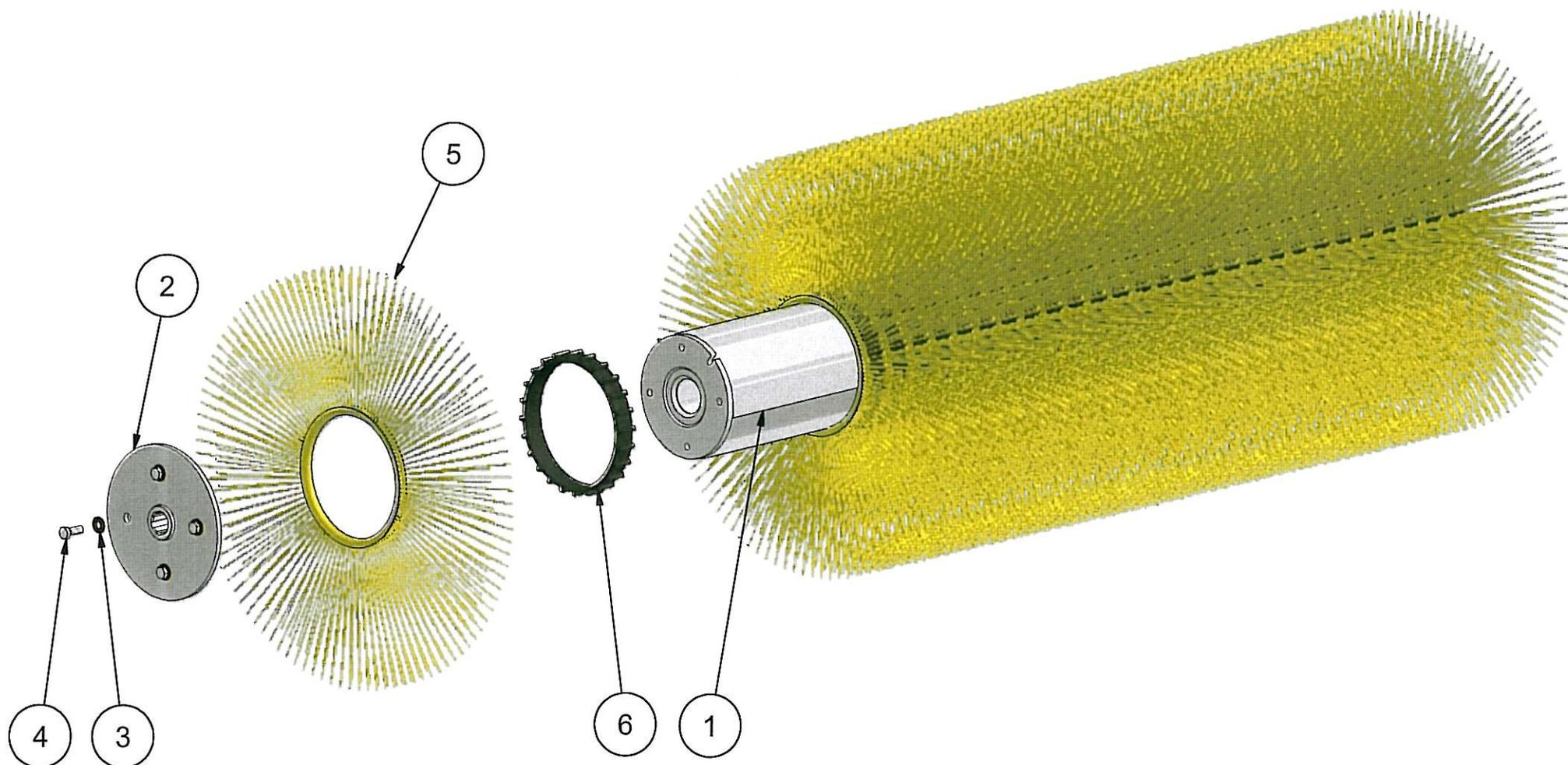

STENSBALLE



Børstevalse type FF/MA

Model 2002

17.03.2010

Pos.	Benævnelse	Antal	Res. nummer	Bemærkning
1	Børstevalse	1	53-111-601	FF 1100 MA
	Børstevalse	1	53-112-601	FF 1200 MA
	Børstevalse	1	53-113-601	FF 1300 MA
	Børstevalse	1	53-115-601	FF 1500 MA
	Børstevalse	1	53-117-601	FF 1700 MA
2	Flangebøsning	2	53-113-602	
3	Contact-skive	8	35-200-010	
4	Sætskrue	8	29-110-030	
5	Polybørste	27	53-007-600	FF 1100 MA
	Polybørste	29	53-007-600	FF 1200 MA
	Polybørste	31	53-007-600	FF 1300 MA
	Polybørste	35	53-007-600	FF 1500 MA
	Polybørste	39	53-007-600	FF 1700 MA
6	Plast afstandsring	26	53-007-030	FF 1100 MA
	Plast afstandsring	28	53-007-030	FF 1200 MA
	Plast afstandsring	30	53-007-030	FF 1300 MA
	Plast afstandsring	34	53-007-030	FF 1500 MA
	Plast afstandsring	38	53-007-030	FF 1700 MA
Antal af børste og afstandsringe kan variere.				

GMR
maskiner a/s



Saturnvej 17 . DK 8700 Horsens
Tlf.: +45 75 64 36 11 . Fax: +45 75 64 53 20
E-mail: stensballe@gmr.dk . http://www.gmr.dk